

ACR™ ROBOT 557 MPA XL



 **CONJET**

ACR™ ROBOT 557 MPA XL

User-friendly with exceptional reach and flexibility

The track-driven Robot 557 MPA XL is equipped with a multi-purpose arm allowing full flexibility. Together with an adjustable chassis, the robot is a versatile and compact solution with extended reach and stability.

Stability is key to secure full safety when operating an ACR™ robot. That is why the Robot 557 MPA XL has been designed with the ability to extend the tracks, as well as sliding the main body - both to shift the robot's center of gravity.

An automatic Stability Control System is incorporated into all 557 MPA XL-robots. The SCS monitors the position of the feed beam and notifies the operator in case of a warning.

FEATURES

- Fully automated via the Conjet ONE control system
- Up to 6,3 m vertical reach
- Main body can slide back up to 400 mm for increased stability
- Tool-kits available ensures multipurpose use
- Diesel or electric power
- Easy access to the engine and hydraulics for daily maintenance
- Automatic Stability Control system
- Prepared for Conjet Connect



Mirrored color display on both machine and remote control for easy configuration and monitoring.



OPTIMAL FOR

- Parking decks
- Bridges
- Tunnels
- High walls
- Quays and docks

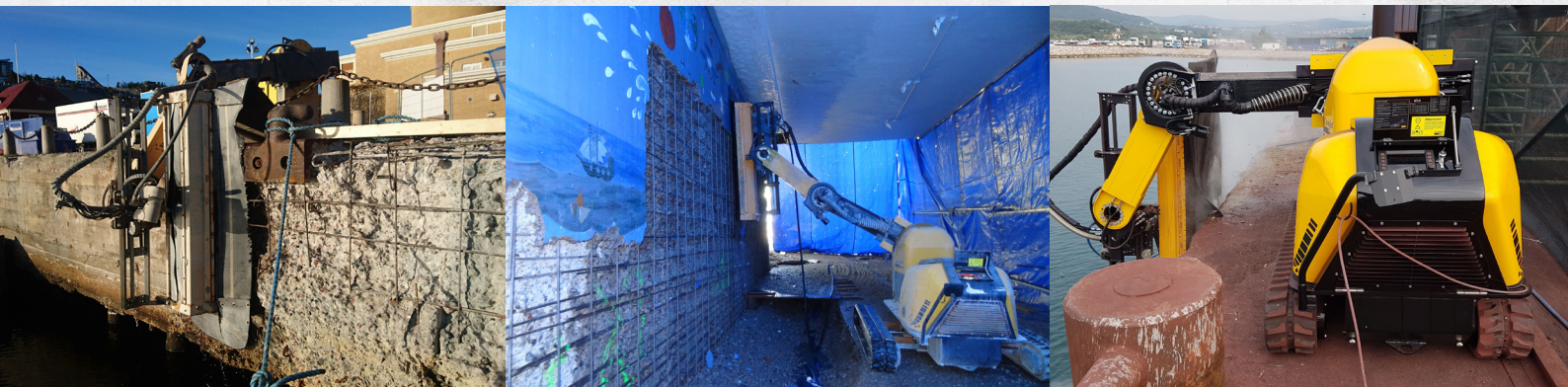

ACR™ ROBOT 557 MPA XL

TECHNICAL DATA

Weight	2 700kg (5 950lb)
Length	3 560mm (11ft 8in)
Width / with extended tracks	1 200mm – 1 900mm (3ft 11in/6ft 3in)
Height, minimum	1 750mm (5ft 9in)
Cutting height - vertical	6 350mm (20ft 10in)
Cutting height overhead	5 900mm (19ft 4in)
Cutting below track level	3 050mm (10ft 1in)
Cutting width	2 100mm (6ft 11in)
Maximum reaction force	3 000N*
Power supply	Diesel engine, 18,7 kW Electric, 3x380-480VAC, 32A or 3x200VAC, 63A / 50-60Hz



CE, EMC certified

*see Operators Manual for detailed instructions



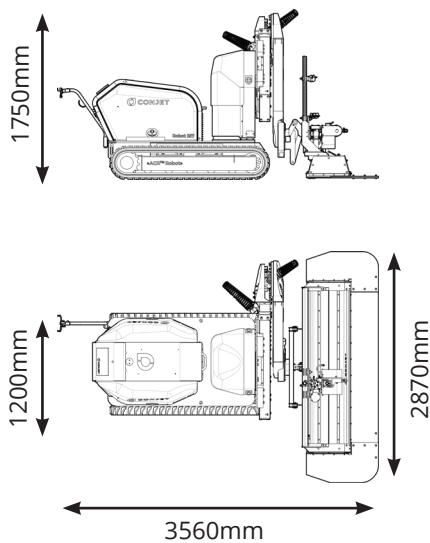

SIZE

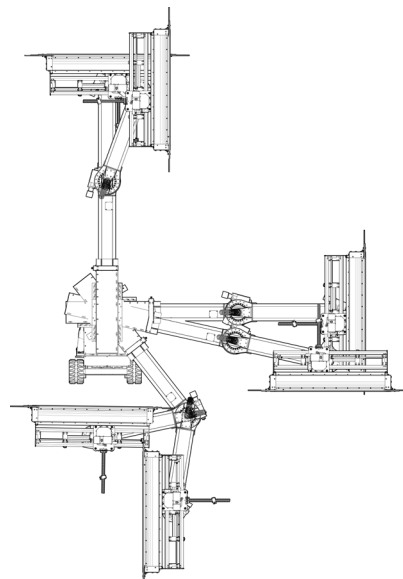

RANGE



CONFIGURATIONS

TOOLS		Feed beam extension
		Rotor
		Ship cleaning / Surface preparation
		Radius

Bridges. Parking Decks. Dams. Tunnels. Piers. If a concrete structure needs repair, Conjet has the optimal concrete removal solution for the task.

For over 35 years, we have led the development of robotic hydrodemolition technology – a technology with a proven track record as the most sustainable and effective method for concrete removal and other types of surface preparation.

We provide world class training and aftersales support for our partners and customers, Team Conjet, to ensure that projects are successfully performed in a safe, precise and efficient manner.

At Conjet, our collective knowledge and expertise has been built into our Automated Concrete Removal robots. Safe for the structure, safe for the operator and safe for the environment.

We call it ACR™



Conjet AB

Anläggsvägen 14
SE-136 25 Haninge
SWEDEN
+46 (0)8 55 65 22 40

Conjet Inc.

3400 Int'l Airport Dr., Ste 100
Charlotte, NC 28208
USA

www.conjet.com | info@conjet.com